

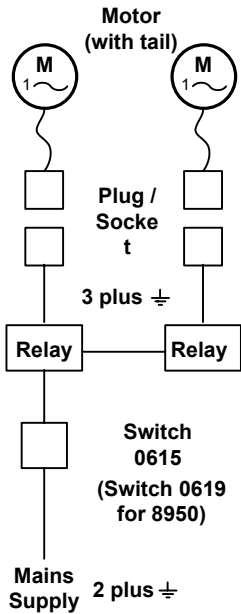

**Important**  
 Plug / socket must be wired correctly with exposed pins on 0544 fitted to motor tail

To reverse Direction of motor on command swap black/brown wires in plug/ socket



- System Motor Ratings( 230v)
- 2150 - 0.7 Amp
  - 2195 - 0.6 Amp
  - 4550 - 0.35 Amp
  - 4580 - 0.3 Amp
  - 4595 - 0.38 Amp
  - 4860 - 0.3 Amp
  - 4870 - 0.38 Amp
  - 4880 - 0.65 Amp
  - 5800 - 2.2 Amp
  - 8800 - 0.66 Amp
  - 8900 - 0.66 Amp
  - 8950 - 0.57 Amp

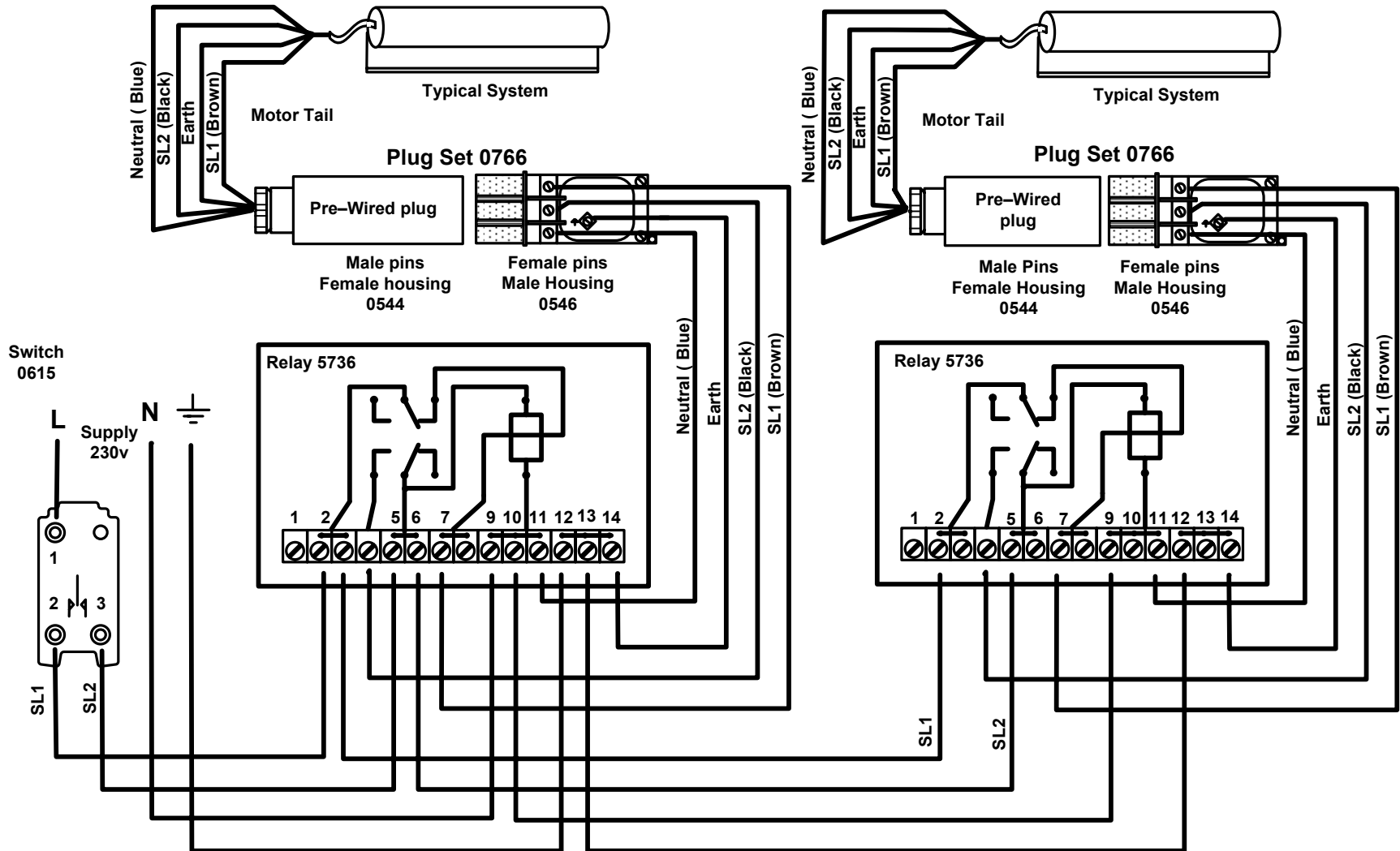

All printed & electronically distributed copies of this drawing are uncontrolled copies

**Silent Gliss Ltd**  
 Poorhole Lane.  
 Broadstairs  
 Kent CT10 2PT  
 Tel 01843 863571  
 Fax 01843 864503  
 E-mail: info@silentgliss.co.uk  
 Web site: www.silentgliss.co.uk

**2 or more Motor from 1 Switch Simultaneously**  
**Systems 2150, 2195, 4550, 4580 4595, 4860, 4870, 4880, 8700, 8800**  
 (Motors must not be wired in parallel.)

System 8950 requires individual control to ensure alignment of slats in banked blinds

Motor Type **A B X**  
 Drawing Number  
**E 102**  
 Issue Date 14-06-07